

IPH Catalog

High-pressure internal gear pumps



Benefits that impress

Internal gear pumps from Voith Turbo are working reliably in hundreds of thousands of machines around the world. Sophisticated technology, robust design and cost-efficient operation have convinced thousands of customers to trust Voith. Based on that trust, we have become the world market leader for high-pressure internal gear pumps with gap compensation.

Features that count

Compact dimensions, low operating noise levels, minimal pressure and volume pulsation and a high degree of efficiency have always been important customer requirements when it comes to using hydraulic pumps. IPH high-pressure pumps with radial and axial sealing gap compensation have been meeting these requirements extremely reliably for many years now.

Machines that run

Rarely seen, but hard at work in countless machines, Voith Turbo internal gear pumps reliably provide high pressures. They are mainly used in the plastic and sheet-metal processing sectors, presses as well as conveying and lifting equipment. The pumps are also in demand for shipbuilding, municipal vehicles, power plants and special machine building.

Contents

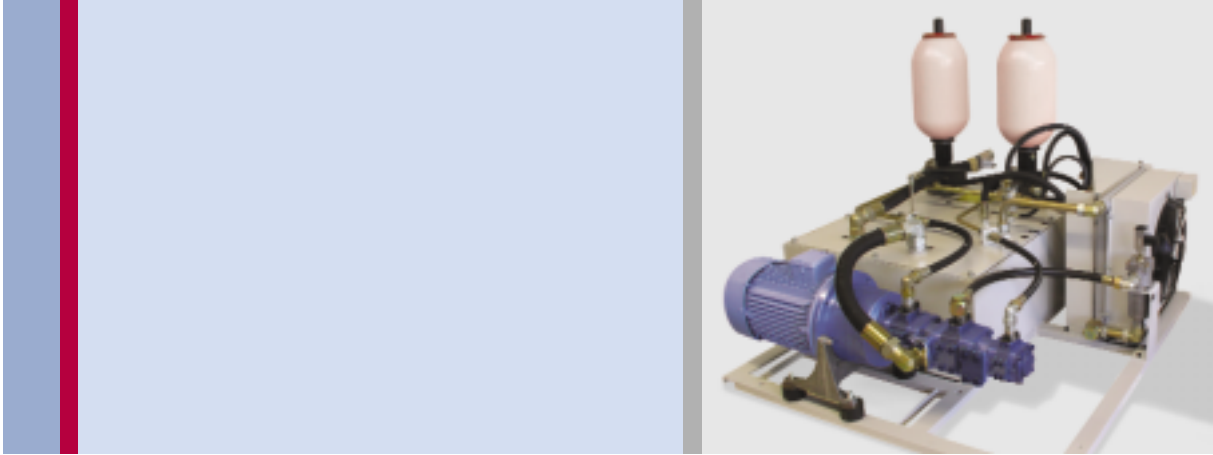

High-pressure pumps in hydraulic units with accumulator charging circuits

	Page
Design and function	3
Performance data	4
IPH 4	6
IPH 5	8
IPH 6	10
SAE suction and pressure flange	12
Type code	13
Order designation	
Multi-flow pumps	14
Pump combinations	
Designs	15

Design and function

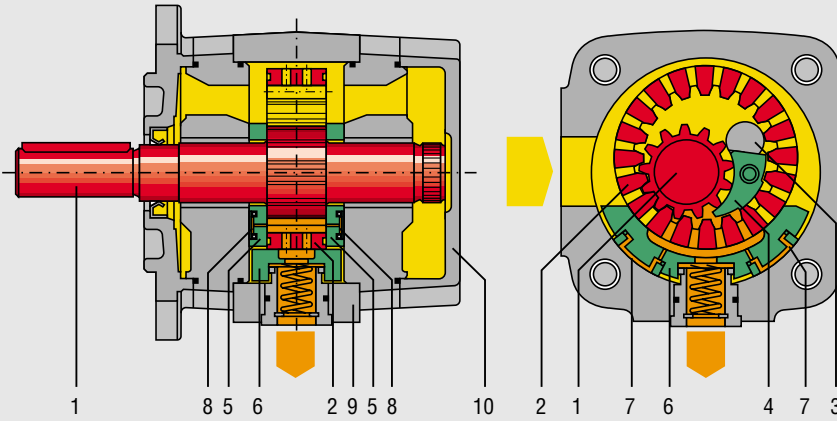

- 1 Pinion shaft
 - 2 Internal gear
 - 3 Filler pin
 - 4 Filler piece
 - 5 Axial disc
 - 6 Control piston
 - 7 Radial pressure field
 - 8 Axial pressure field
 - 9 Housing
 - 10 End cover with bleeder screw
- Suction chamber
■ Pressure chamber

Design features

- Internal gear principle
- Plain bearings
- Radial and axial sealing gap compensation

Product characteristics

- Long service life
- High volumetric efficiency
- High overall efficiency
- Very low flow and pressure pulsation
- Low noise levels
- Compact dimensions
- Low weight
- Wide speed range
- Excellent suction properties
- High permitted viscosity
- Simple maintenance
- Multiple pumps and pump combinations are possible
- Suitable for variable-speed drives (variable volume flow)
- Motor operation possible (energy recovery)

Function

Rotation of the gears within the pump draws in the pressure fluid (usually hydraulic oil) into the space between the pinion and internal gear. The two smooth running gears help to ensure excellent suction behavior.

In the radial direction, the gears chambers are sealed by gear meshing and the filler piece. In the axial direction, the axial plates seal the pressure chamber with the minimal possible gap. This design minimizes volume losses and increases efficiency.

When the gears rotate, the pinion teeth enter the gaps between the internal gear teeth and displace the pressure fluid.

Combinations

IPH pumps can be combined to form dual or multi-flow pumps. Combinations with other Voith Turbo pump series are also possible. Used in conjunction with pumps from the medium and low-pressure series, Voith equipment can handle a wide range of potential applications.

For further information on possible combinations, see page 14 and our brochure No. G1714 (Voith multi-flow pumps).

Combinations with third-party products are generally possible. Please contact your Voith Turbo representative for more information.

Variable volume flow

We supply complete hydraulic units with IPH pumps, asynchronous motors and frequency converters (EPA/EPAF system) to generate variable volume flows. For further information, see our brochure No. G1420 (Voith EPA System).

Performance data

Technical data		Calculations	
Design	Internal gear pump with radial and axial sealing gap compensation	Delivery	$Q = V_{g\ th} \cdot n \cdot \eta_v \cdot 10^{-3}$ [l/min]
Type	IPH	Power	$P = \frac{Q \cdot \Delta p}{600 \cdot \eta_g}$ [kW]
Mounting types	SAE hole flange; ISO 3019/1	$V_{g\ th}$	Pump volume per revolution [cm ³]
Line mounting	SAE suction and pressure flange J 518 C code 61	n	Speed [min ⁻¹]
Rotation direction	clockwise or anti-clockwise	η_v	Volumetric efficiency
Mounting position	any	η_g	Overall efficiency
Shaft load	For details of radial and axial drive shaft loads, please contact your Voith Turbo representative	Δp	Differential pressure [bar]
Input pressure	0.8 – 3 bar absolute pressure (at start, briefly 0.6 – 3 bar)		
Pressure fluid	HLP mineral oils DIN 51524, part 2 or 3		
Viscosity range of the pressure fluid	10 – 300 mm ² s ⁻¹ (cSt)		
Permissible start viscosity	max. 2000 mm ² s ⁻¹ (cSt)		
Permissible temperature of the pressure fluid	-20 – +80 °C		
Necessary purity of the pressure fluid in accordance with NAS 1638	Class 8		
Filtration	Filtration quotient min. $\beta_{20} \geq 75$, recommended $\beta_{10} \geq 100$ (longer service life)		
Permissible ambient temperature	-10 – +60 °C		

Characteristics

Type, size- delivery	Displacement per revolution	Speed		Delivery at 1500 min ⁻¹	Pressures within the range n _{min} ...n _{max}	
		min.	max.		Continuous pressure	Peak pressure
	[cm ³]	[min ⁻¹]	[min ⁻¹]	[l/min]	[bar]	[bar]
IPH 4 – 20	20.7	300	3000	31.0	300	330
IPH 4 – 25	25.7	300	3000	38.6	250	315
IPH 4 – 32	32.3	300	3000	48.5	250	300
IPH 5 – 40	40.8	300	3000	61.2	300	330
IPH 5 – 50	50.3	300	3000	75.4	250	315
IPH 5 – 64	63.9	300	3000	95.8	250	300
IPH 6 – 80	81.3	300	2500	121.9	300	330
IPH 6 – 100	101.6	300	2500	152.4	250	315
IPH 6 – 125	125.6	300	2500	188.8	250	300

The values given apply for:

- Pumping of mineral oils with a viscosity of 20...40 mm²s⁻¹
- An input pressure of 0.8...3.0 bar absolute pressure

Notes:

- Peak pressures apply to 15% of operating time and a maximum cycle time of 1 minute.
- Please enquire about pressures at speeds lower than n_{min}.
- Due to production tolerances, the pump volume may be approx. 1.5% lower.

IPH 4

Standard designs

Design and dimensions

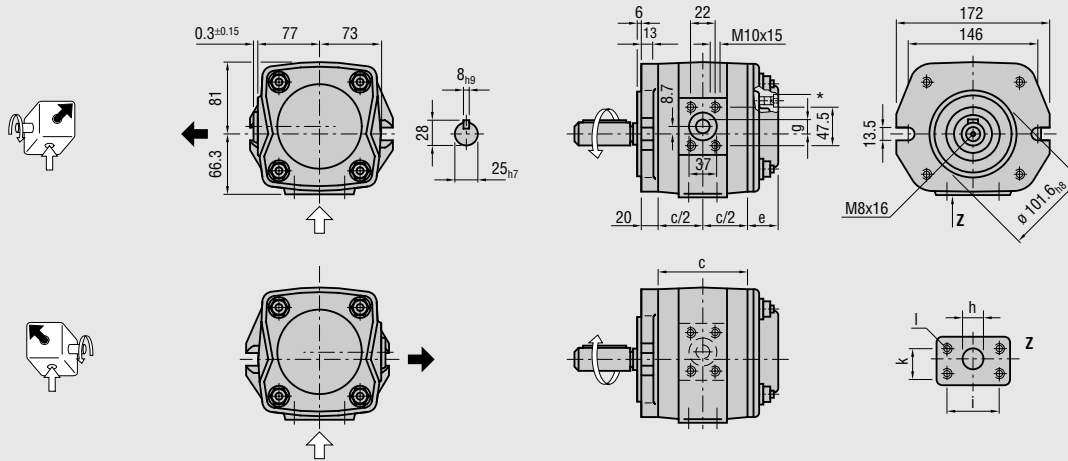

* The plug screw must be closed during operation. Ensure the M10x1 plug screw, hexagon socket SW5, is tightened to a torque of 10 Nm. Depending on the pump position, filling or ventilation is possible with the M10x1 plug screw prior to commissioning.

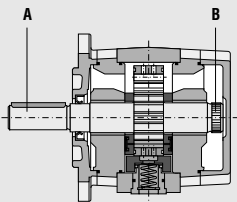

Design	Dimensions							Weight m [kg]	SAE flange no.	
	c	e	g	h	i	k	l		↑	↓
	[mm]	[mm]	[mm]	[mm]	[mm]	[mm]	Thread			
IPH 4 – 20	102	36	19	30	58.7	30.2	M10x15	13.5	11	13
IPH 4 – 25	108	36	21	30	58.7	30.2	M10x15	14.2	11	13
IPH 4 – 32	116	36	24	32	58.7	30.2	M10x15	15.0	11	13

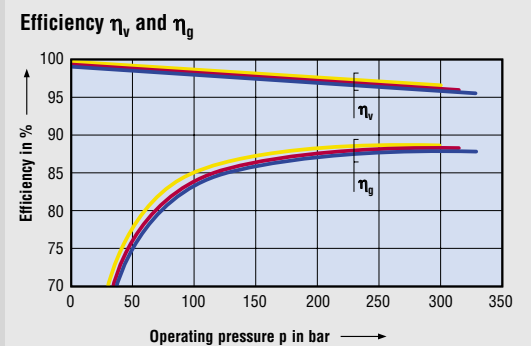
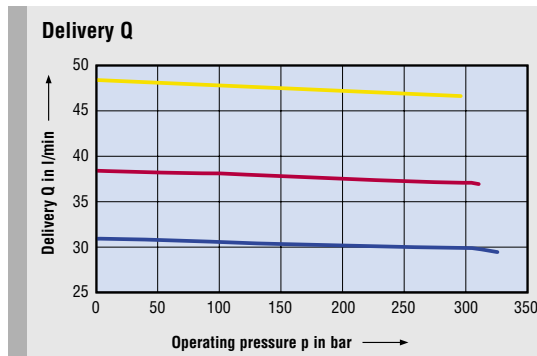

Permitted input torques:

Input shaft A: 450 Nm
Secondary shaft B: 300 Nm

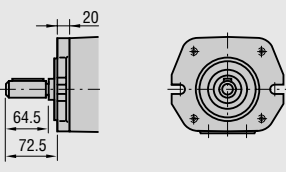
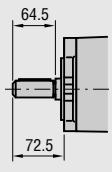

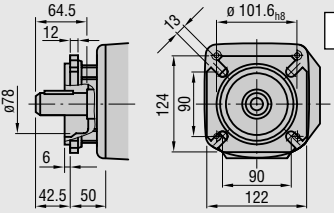
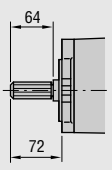
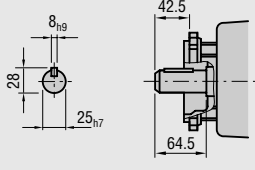
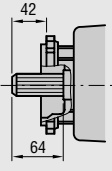
Type	Pump sizes	Rotation, suction connection	Mounting flange	Shaft end
IPH 4	20 25 32	Standard		
		Clockwise rotation, radial suction port  1	SAE 2-hole flange, dimensions on left  0	Parallel shaft with keyway connection, dimensions on left  1
		Variants		
	Anti-clockwise rotation, radial suction port  6	SAE 4-hole flange  1	Involute gearing with 2-hole SAE flange ANSI B92.1a 13T 16/32 DP 30°  0	
			Involute gearing with 2-hole SAE flange ANSI B92.1a 13T 16/32 DP 30°  1	
			Involute gearing with 2-hole SAE flange ANSI B92.1a 13T 16/32 DP 30°  1	

Designation according to type code

Type code/order designation, see page 13

Input power P

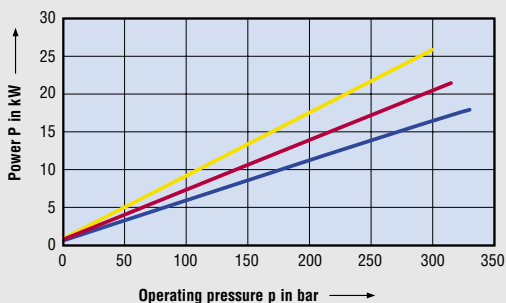

Airborne noise level

Measurement site 1 m axial

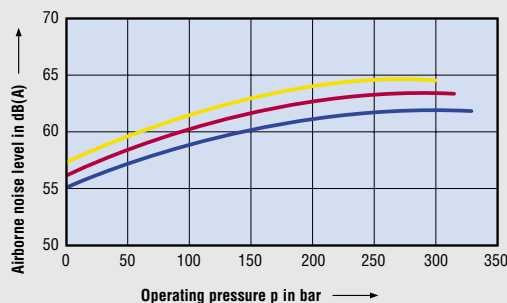

Measurement conditions:

Speed: 1500 min⁻¹
Viscosity of pressure fluid: 46 mm²s⁻¹
Operating temperature: 40 °C

Characteristic curves:

- IPH 4 – 20
- IPH 4 – 25
- IPH 4 – 32

Note: Measurement taken in a low-noise room.

In an anechoic room, the measurements are approx. 5 dB(A) lower.

IPH 5

Standard designs

Design and dimensions

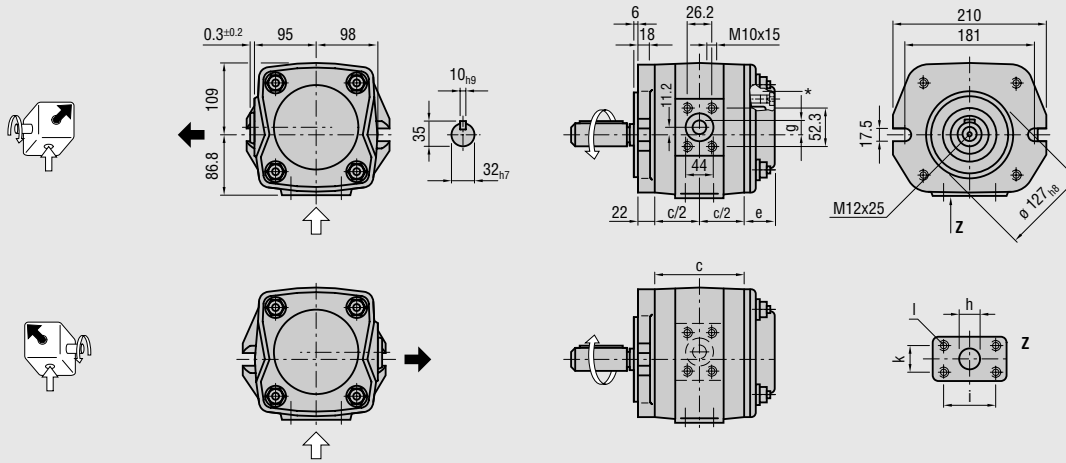

* The plug screw must be closed during operation. Ensure the M10x1 plug screw, hexagon socket SW5, is tightened to a torque of 10 Nm. Depending on the pump position, filling or ventilation is possible with the M10x1 plug screw prior to commissioning.

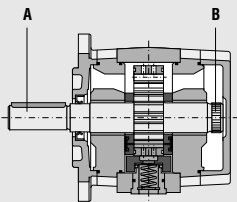

Design	Dimensions							Weight m [kg]	SAE flange no.	
	c	e	g	h	i	k	l		▲	▼
	[mm]	[mm]	[mm]	[mm]	[mm]	[mm]	Thread			
IPH 5 – 40	138	35	24	35	70	36	M12x19	26.8	12	30
IPH 5 – 50	145	35	27	42	70	36	M12x19	28.3	12	30
IPH 5 – 64	155	35	29	42	70	36	M12x19	30	12	30

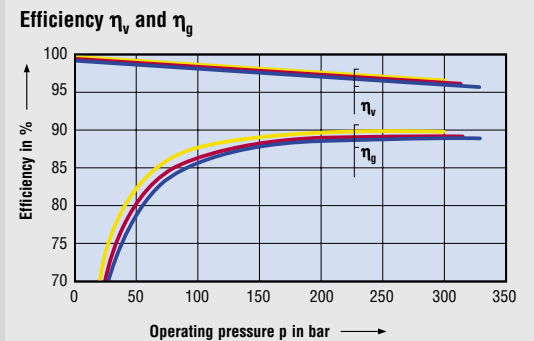
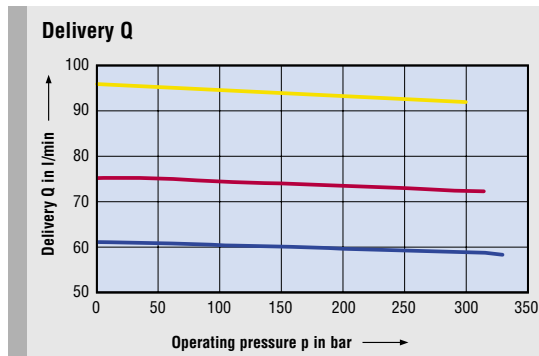

Permitted input torques:

Input shaft A: 800 Nm
Secondary shaft B: 540 Nm

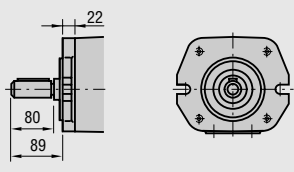
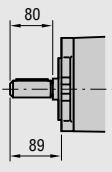

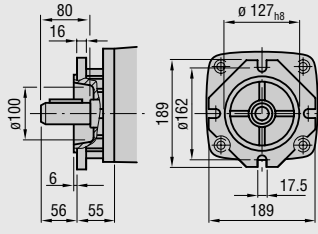
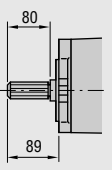
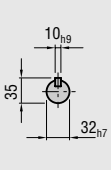
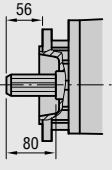
Type	Pump sizes	Rotation, suction connection	Mounting flange	Shaft end
IPH 5	40 50 64	Standard		
		Clockwise rotation, radial suction port  1	SAE 2-hole flange, dimensions on left  0	Parallel shaft with keyway connection, dimensions on left  1
		Variants		
	Anti-clockwise rotation, radial suction port  6	SAE 4-hole flange  1	Involute gearing with 2-hole SAE flange ANSI B92.1a 14T 12/24 DP 30°  0	 1
			Involute gearing with 2-hole SAE flange ANSI B92.1a 14T 12/24 DP 30°  1	

Designation according to type code

Type code/order designation, see page 13

Input power P

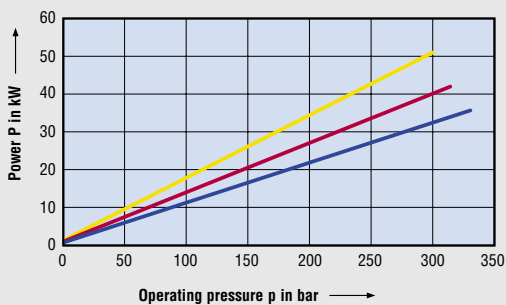

Airborne noise level

Measurement site 1 m axial

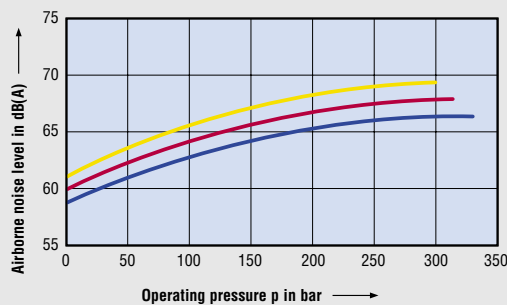

Measurement conditions:

Speed: 1500 min⁻¹
Viscosity of pressure fluid: 46 mm²s⁻¹
Operating temperature: 40 °C

Characteristic curves:

- IPH 5 – 40
- IPH 5 – 50
- IPH 5 – 64

Note: Measurement taken in a low-noise room.

In an anechoic room, the measurements are approx. 5 dB(A) lower.

IPH 6

Standard designs

Design and dimensions

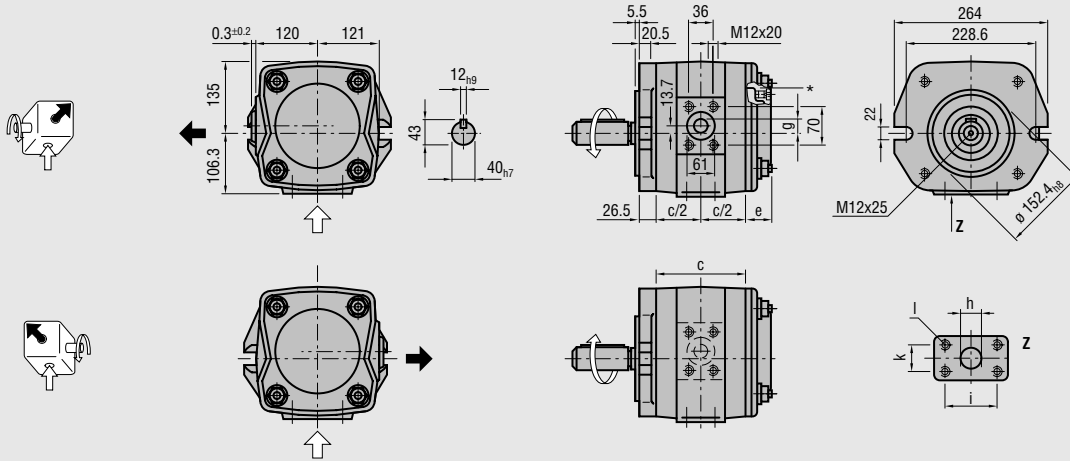

* The plug screw must be closed during operation. Ensure the M10x1 plug screw, hexagon socket SW5, is tightened to a torque of 10 Nm. Depending on the pump position, filling or ventilation is possible with the M10x1 plug screw prior to commissioning.

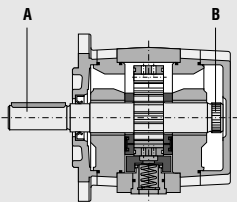

Design	Dimensions								Weight		SAE flange no.	
	c	e	g	h	i	k	l	m	↑	↓		
	[mm]	[mm]	[mm]	[mm]	[mm]	[mm]	Thread					
IPH 6 – 80	171	49	32.5	50	77.8	42.9	M12x23	50.5	14	15		
IPH 6 – 100	181	49	36	50	77.8	42.9	M12x23	54	14	15		
IPH 6 – 125	193	47	39	50	77.8	42.9	M12x23	58	14	15		

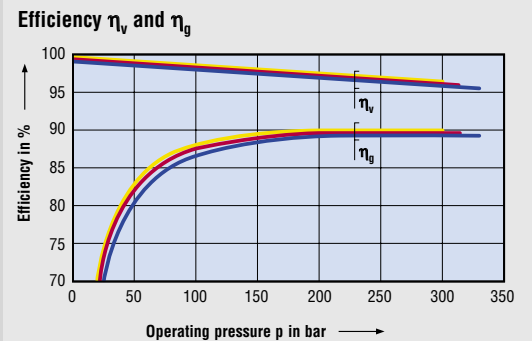
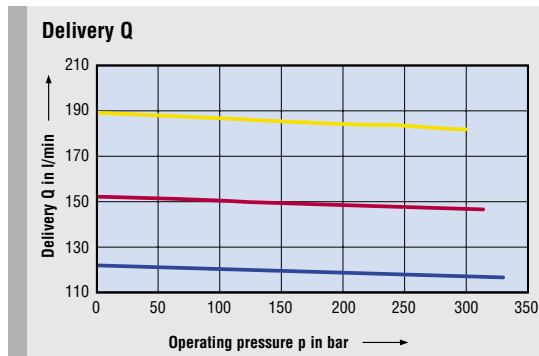

Permitted input torques:

Input shaft A: 1350 Nm
Secondary shaft B: 800 Nm

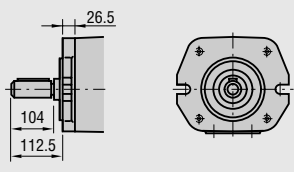
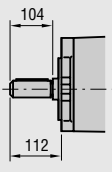

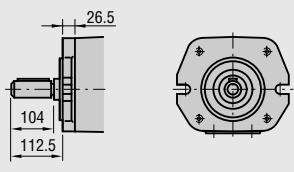
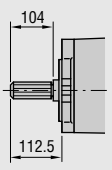
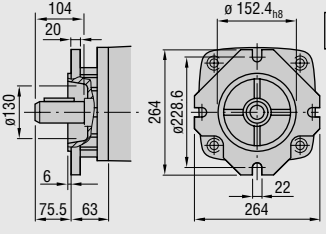
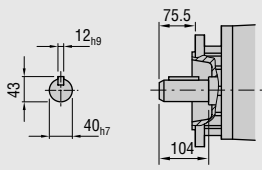
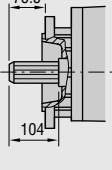
Type	Pump sizes	Rotation, suction connection	Mounting flange	Shaft end
IPH 6	80 100 125	Standard		
		Clockwise rotation, radial suction port  1	SAE 2-hole flange, dimensions on left  0	Parallel shaft with keyway connection, dimensions on left  1
		Variants		
		Anti-clockwise rotation, radial suction port  6	SAE 2-hole flange  0	Involute gearing with 2-hole SAE flange  ANSI B92.1a 13T 8/16 DP 30° 0
			SAE 4-hole flange  1	Involute gearing with 2-hole SAE flange  ANSI B92.1a 13T 8/16 DP 30° 1
				Involute gearing with 2-hole SAE flange  ANSI B92.1a 13T 8/16 DP 30° 1

Designation according to type code

Type code/order designation, see page 13

Input power P

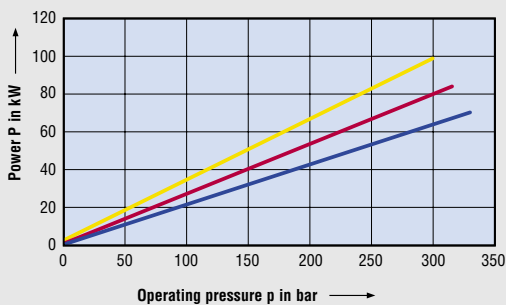

Airborne noise level

Measurement site 1 m axial

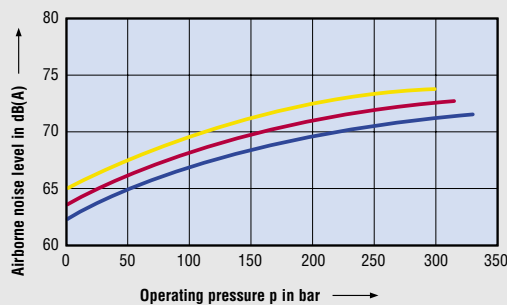

Measurement conditions:

Speed: 1500 min⁻¹
Viscosity of pressure fluid: 46 mm²s⁻¹
Operating temperature: 40 °C

Characteristic curves:

- IPH 6 – 80
- IPH 6 – 100
- IPH 6 – 125

Note: Measurement taken in a low-noise room.

In an anechoic room, the measurements are approx. 5 dB(A) lower.

SAE suction and pressure flanges

according to SAE J 518 C code 61

SAE flange, single-piece

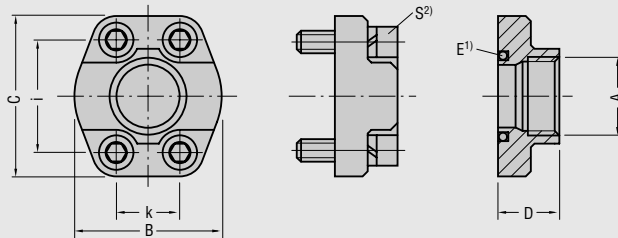

SAE flange no.	A	B	C	D	E ¹⁾	i	k	S ²⁾	max. pressure
	Thread	[mm]	[mm]	[mm]	Seal ring	[mm]	[mm]	Thread	[bar]
10	G 1/2	46	54	36	18.66 – 3.53	38.1	17.5	M 8	345
11	G 3/4	50	65	36	24.99 – 3.53	47.6	22.2	M 10	345
12	G 1	55	70	38	32.92 – 3.53	52.4	26.2	M 10	345
13	G 1-1/4	68	79	41	37.69 – 3.53	58.7	30.2	M 10	276
14 ³⁾	G 1-1/2	82	98	50	47.22 – 3.53	70	36	M 12	345 ³⁾
30	G 1-1/2	78	93	45	47.22 – 3.53	70	36	M 12	207
15	G 2	90	102	45	56.74 – 3.53	77.8	42.9	M 12	207
16	G 2-1/2	105	114	50	69.44 – 3.53	89	50.8	M 12	172
17	G 3	124	134	50	85.32 – 3.53	106.3	62	M 16	138
18	G 4	146	162	48	110.72 – 3.53	130	77.8	M 16	34

¹⁾ Round seal ring (O-ring) ISO-R 1629 NBR

²⁾ Machine screw EN ISO 4762

³⁾ Special design, deviating from SAE J 518 C code 61

Type code

Order designation

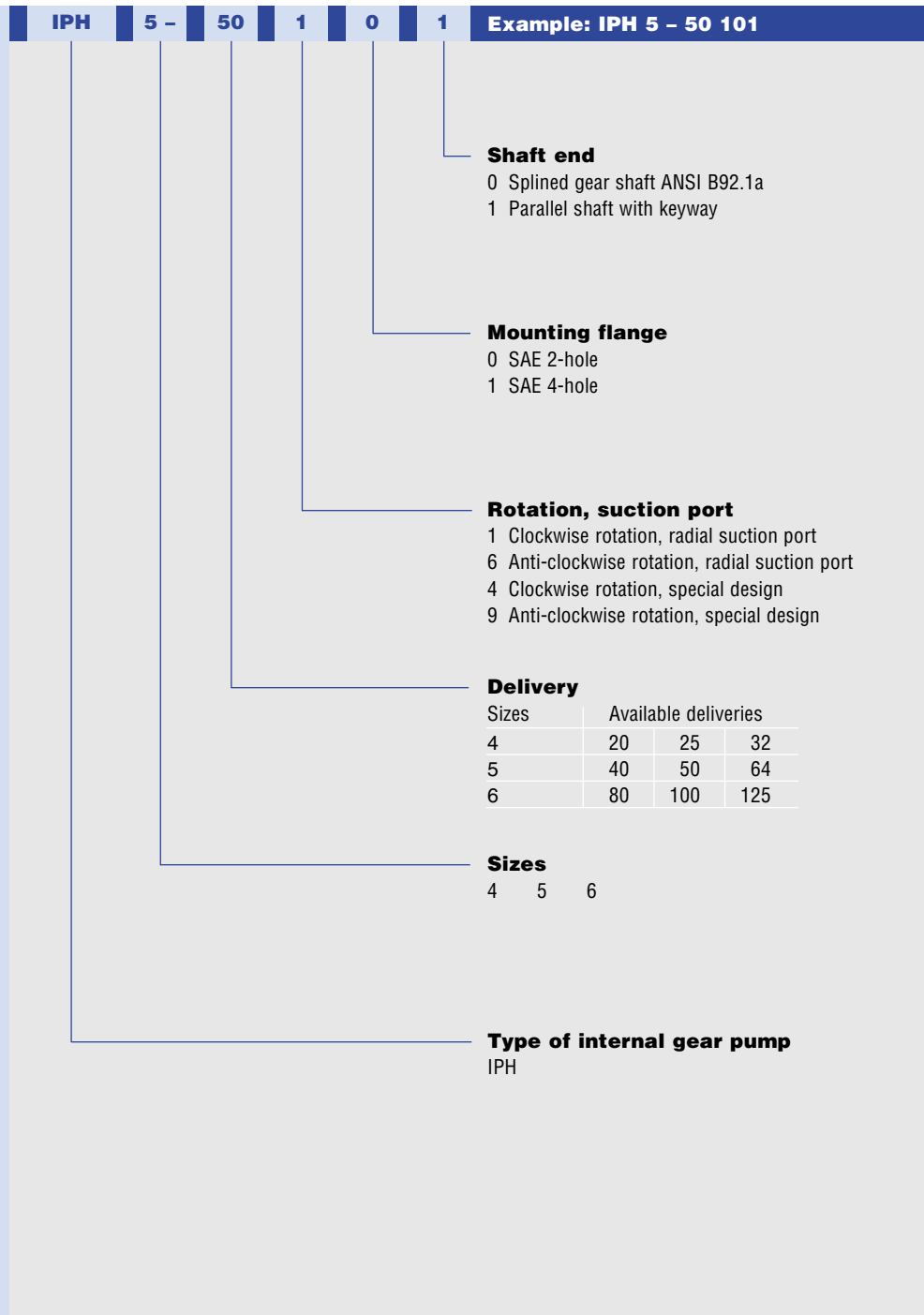

Multi-flow pumps

Pump combinations

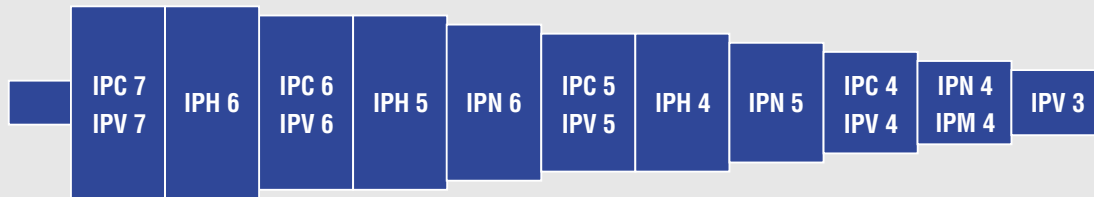

Pump combinations in order of type and size

Combinations of IPH pumps

- IPH pumps of identical or different sizes can be combined to form multi-flow pumps.
- All sizes with each displacement are available as two or three-flow pumps; four-flow pumps must be designed by Voith Turbo.
- The pumps are arranged in increasing order according to size and delivery.

Combination of IPH/IP...-pumps

- It is possible to combine IPH pumps with other Voith Turbo pump series (e.g. medium-pressure pumps IPC/IPM or low-pressure pumps IPN).
- The pumps are arranged by type and size, as shown in the illustration above.
- If identical types or identical sizes follow each other, the pump with the higher pump flow is placed closer to the drive.











Selection

1. Identify the pressure ranges and then choose the appropriate pump series.
2. Identify the deliveries, and then select the appropriate size(s).
3. Define the sequence of the pumps.
4. Check the torque.
5. Determine the direction of rotation and suction.
6. Specify the mounting flange and shaft end.

Connection, assembly

- As a rule, multi-flow pumps are mounted to the drive using a flange. All information on flange designs and shaft ends is contained in the relevant pump series catalog.
- For further relevant information, such as how to determine the adapter housing, see brochure No. G 1714 (Voith Multi-Flow Pumps).

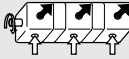
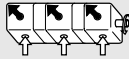
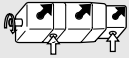
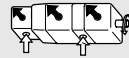
Designs

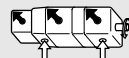
Rotation and suction	Mounting flange	Shaft end
<p>clockwise   anti-clockwise</p>  <div style="display: inline-block; margin: 0 10px; border: 1px solid black; padding: 2px 5px;">1</div> <div style="display: inline-block; margin: 0 10px; border: 1px solid black; padding: 2px 5px;">6</div> 	 <div style="display: inline-block; margin: 0 10px; border: 1px solid black; padding: 2px 5px;">0</div>  <div style="display: inline-block; margin: 0 10px; border: 1px solid black; padding: 2px 5px;">1</div>  <div style="display: inline-block; margin: 0 10px; border: 1px solid black; padding: 2px 5px;">1</div>	 <div style="display: inline-block; margin: 0 10px; border: 1px solid black; padding: 2px 5px;">1</div>  <div style="display: inline-block; margin: 0 10px; border: 1px solid black; padding: 2px 5px;">0</div>
 <div style="display: inline-block; margin: 0 10px; border: 1px solid black; padding: 2px 5px;">1</div> <div style="display: inline-block; margin: 0 10px; border: 1px solid black; padding: 2px 5px;">6</div> 	<div style="display: inline-block; border: 1px solid black; padding: 2px 5px;">0</div> <div style="display: inline-block; margin: 0 10px; border: 1px solid black; padding: 2px 5px;">1</div> <div style="display: inline-block; border: 1px solid black; padding: 2px 5px;">1</div>	<div style="display: inline-block; border: 1px solid black; padding: 2px 5px;">1</div> <div style="display: inline-block; border: 1px solid black; padding: 2px 5px;">0</div>
 <div style="display: inline-block; margin: 0 10px; border: 1px solid black; padding: 2px 5px;">3</div> <div style="display: inline-block; margin: 0 10px; border: 1px solid black; padding: 2px 5px;">8</div> 		
 <div style="display: inline-block; margin: 0 10px; border: 1px solid black; padding: 2px 5px;">3</div> <div style="display: inline-block; margin: 0 10px; border: 1px solid black; padding: 2px 5px;">8</div> 	<p>For designs and dimensions, see catalog of the relevant pump series.</p>	<p>For designs and dimensions, see catalog of the relevant pump series.</p>
<p>Special design <div style="display: inline-block; margin: 0 10px; border: 1px solid black; padding: 2px 5px;">4</div> <div style="display: inline-block; margin: 0 10px; border: 1px solid black; padding: 2px 5px;">9</div> Special design</p>	<div style="display: inline-block; border: 1px solid black; padding: 2px 5px;">0</div> SAE 2- hole flange <div style="display: inline-block; border: 1px solid black; padding: 2px 5px;">1</div> SAE 4-hole flange	

Voith Turbo GmbH & Co. KG
Hydrostatics
Alexanderstr. 2
89522 Heidenheim, Germany
Tel. +49 7321 37-4573
Fax +49 7321 37-7809
hydrostatik@voith.com
www.voithturbo.com/hydrostatics.htm

Voith internal gear pumps
used around the world

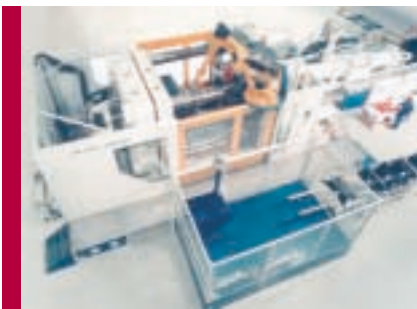

Plastics injection molding machine



Folding press



Punching press



Hydraulic unit



Lifting platform



Marine applications

Additional applications:

- Die-casting machines
- Packing presses
- Shears
- Ground drilling machines
- Test rigs
- Hydraulic presses
- Crane building
- Lifting devices
- Garbage collection vehicles

VOITH
Engineered reliability.